

DOUBLE OPEN THROAT INTAKE SMALL BOX DESIGN DETAILS

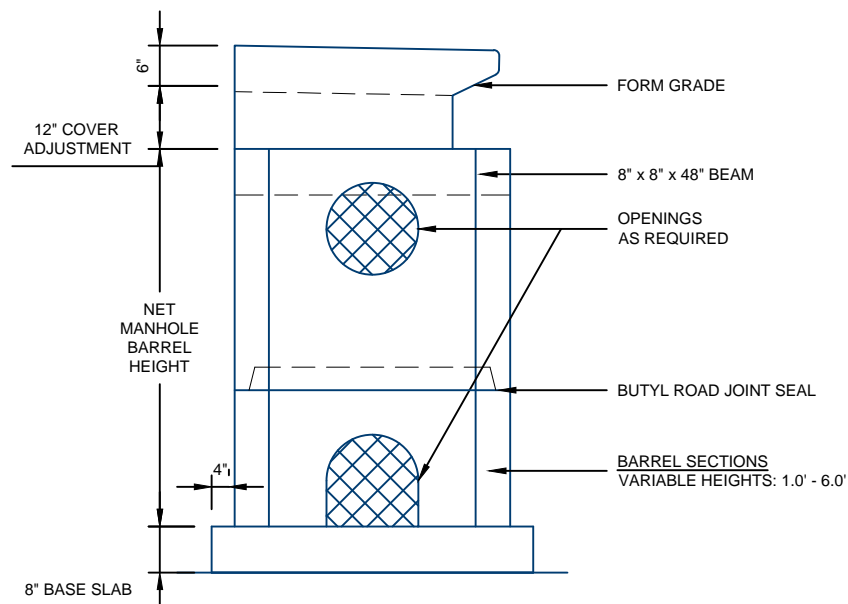
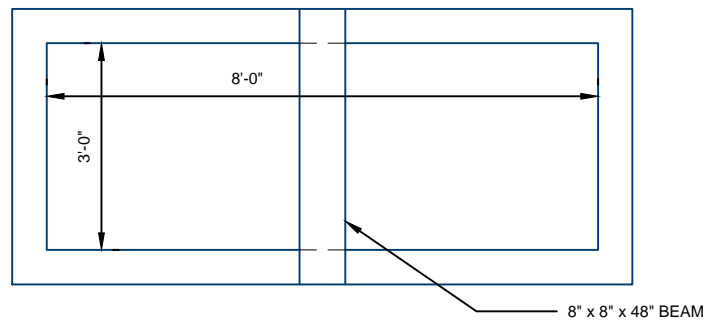

NOTES:

1. ALL COMPONENTS ARE MANUFACTURED PER SUDAS SW-509

For more information about our products please contact us at:
(712) 665-2822

www.hancockconcrete.com

© 2015 Hancock Concrete Products, LLC